

NOISE CONTROL OF VEHICLE DRIVE SYSTEMS

UDC 534.2+681.5

Ulrich Gabbert, Fabian Duvigneau, Stefan Ringwelski

Otto-von-Guericke-University Magdeburg, Magdeburg, Germany

Abstract. *The paper presents an overall simulation approach to control the noise emission of car engines at a very early stage of the design process where no real prototypes are available. The suggested approach combines different physical models and couples different software tools such as multi-body analysis, fluid dynamics, structural mechanics, magneto-electrodynamics, thermodynamics, acoustics and control as well. The general overall simulation methodology is presented first. Then, this methodology is applied to a combustion engine in order to improve its acoustical behavior by passive means, such as changing the stiffness and the use of damping materials to build acoustic and thermal encapsulations. The active control by applying piezoelectric patch actuators at the oil sump as the noisiest part of the engine is discussed as well. The sound emission is evaluated by hearing tests and a mathematical prediction model of the human perception. Finally, it is shown that the presented approach can be extended to electric engines, which is demonstrated at a newly developed electric wheel hub motor.*

Key Words: *Acoustics, Combustion Engines, Active Noise Reduction, Sound Absorption, Engine Encapsulations, Electric Wheel Hub Motor, Finite Element Method, Measurements*

1. INTRODUCTION

In recent years, increasing attention has been paid to vibration and acoustic noise control in many industrial applications, especially in automotive industries. The control of noise and vibration is essential since it contributes to comfort, efficiency and safety. There are two different approaches to achieve noise and vibration attenuation. On the one hand, there is a widely used passive approach. Passive control techniques mostly reduce vibration and sound emission of the structures by modifying the structural geometry and by applying additional damping materials. These methods are best suited for a higher

Received June 15, 2017 / Accepted July 11, 2017

Corresponding author: Gabbert, Ulrich

Affiliation: Otto-von-Guericke-Universität Magdeburg, Universitätsplatz 2, D-39106 Magdeburg

E-mail: ulrich.gabbert@ovgu.de

frequency range. A drawback of the damping materials is the increase in weight. An overview of the developments in structural design optimization for the passive noise control can be found in Marburg [21]. On the other hand, there are active control techniques available, which provide an alternative way to minimize unwanted structural vibrations and noise. Active methods are of increasing interest to designers since they are powerful and do not increase structural weight considerably. A first comprehensive overview of the active control of sound is given by Nelson [25]. A very beneficial active vibration control technique was first introduced by Fuller et al. [7]. In his concept actuators are directly attached to a structure in order to reduce sound radiation by changing its vibration behavior. Piezoelectric ceramics are widely used as sensors and actuators because they can easily be mounted onto the vibrating structure [30]. Active control techniques are usually employed in a low frequency range. Over the past years, several researchers have studied different control strategies for active structural control [9, 10, 13, 18]. Li et al. [19] and Ringwelski et al. [30-32] applied a velocity feedback control algorithm to a rectangular fluid-loaded plate with piezoelectric layers, which has been proven to be a robust and effective control strategy. Ruckman and Fuller [33] applied a feedforward control approach to reduce actively the acoustic radiation of a fluid-loaded spherical shell structure. Orszulik et al. applied a feedforward/feedback control design for a piezoelectric nanopositioning platform [28]. A linear quadratic optimal control (LQ) technique combined with additional dynamics was proposed by Nestorović et al. [23] and successfully applied to control the vibration of a car roof [24]. Orszulik and Gabbert [27] have proposed a data interface for coupling commercial finite element software and control design software. This allows hardware in the loop approaches to design active controlled structures.

In comparison to the active approaches the passive damping of structures to reduce the noise radiation by design modifications and the application of additional damping materials is much more pronounced, due to its simpler and cheaper application and a more robust noise reduction effect even in changing environmental conditions.

The development and industrial application of noise reduction techniques require efficient and reliable simulation tools to design an acoustically optimized system. Virtual models are of particular interest in the design process since they enable the designer to optimize a technical system by a so called virtual twin.

The focus of the paper at hand is to improve the acoustic behavior of vehicle engines, where passive methods as well as active ones are taken into account. Besides the engine noise there are several other noise sources of vehicles such as the noise excited from the interaction between the tires and the road surfaces (rolling noise) and the excitation of the car body by the air stream around the vehicle. Such sources are not discussed in this paper.

The paper is organized as follows. At first the overall acoustic simulation approach is briefly presented. Then, it is applied to combustion engines, where several simulation results are presented to underline the complexity but also to demonstrate the advantages of the developed simulation approach. It is briefly shown that the active control methods are also advantageous for noise radiation reduction, especially in a lower frequency range. The calculated sound pressure distribution in the air surrounding the engine does not represent the human perception of the sound, which can lead to very different results in the sound design. Therefore, an approach is presented, which enables the designer to develop a virtual sound design on simulation results only, without having a real prototype at hand. As an outlook to the ongoing research activities it is shown that acoustic problems

are not automatically solved by a change to electro drive systems. Measurements at prototypes of a newly developed wheel hub motor have shown a significant high frequency noise radiation, which was the motivation to extend and apply a developed overall simulation approach to electrical machines as well.

2. CONCEPT OF AN OVERALL ACOUSTIC SIMULATION APPROACH

In today's design process of engines acoustics is taken into account in a very late development stage, where first acoustics measurements can be performed at the final prototype of an engine. At this development stage the possible changes of the engine design are very limited, and, consequently, it is impossible to receive an optimal acoustic solution. To overcome this problem acoustics should be evaluated very early in the design process, where no prototype exists. But this requires a holistic virtual engineering workflow of the design process, including models to simulate

- (i) the excitation of the engine,
- (ii) the vibration of all required engine parts,
- (iii) the acoustic pressure wave propagation in the surrounding air, and,
- (iv) the psychoacoustic evaluation of the sound.

Such an overall simulation approach for a combustion engine is shown in Fig. 1. The only input is the gas pressure in the cylinders, which excites the movement of the pistons. By applying an elastic multi-body simulation the vibration excitation of the crankcase can be analyzed. The elastic multi-body simulation (MBS) results in bearing forces as well as in deformations of the cylinder walls. The deformations result from lateral and tilting motions of the piston due to the combustion process respective to the thereby generated gas forces. The resulting superposed load on the cylinder walls is not measureable. Consequently, the presented approach provides, on the one hand, an opportunity to substitute the experimental determination of the engine structure excitation and, on the other hand, it enables consideration of a more realistic vibration excitation. Based on a complex finite element model (FEM) the dynamic behavior of the crankcase can be analyzed, which results finally in the surface velocity, which excites the surrounding air volume. Based on the solution of the acoustic wave equation the pressure waves in the surrounding air volume can be calculated.

From our experiences, the A-weighted acoustic pressure is not sufficient to evaluate the hearing sensation. Consequently, as a final step a model based psychoacoustic assessment is performed. Based on the briefly presented methodology the acoustic behavior of an engine can be evaluated and improved in a virtual development step without the existence of a real prototype, which is shown in the next chapters.

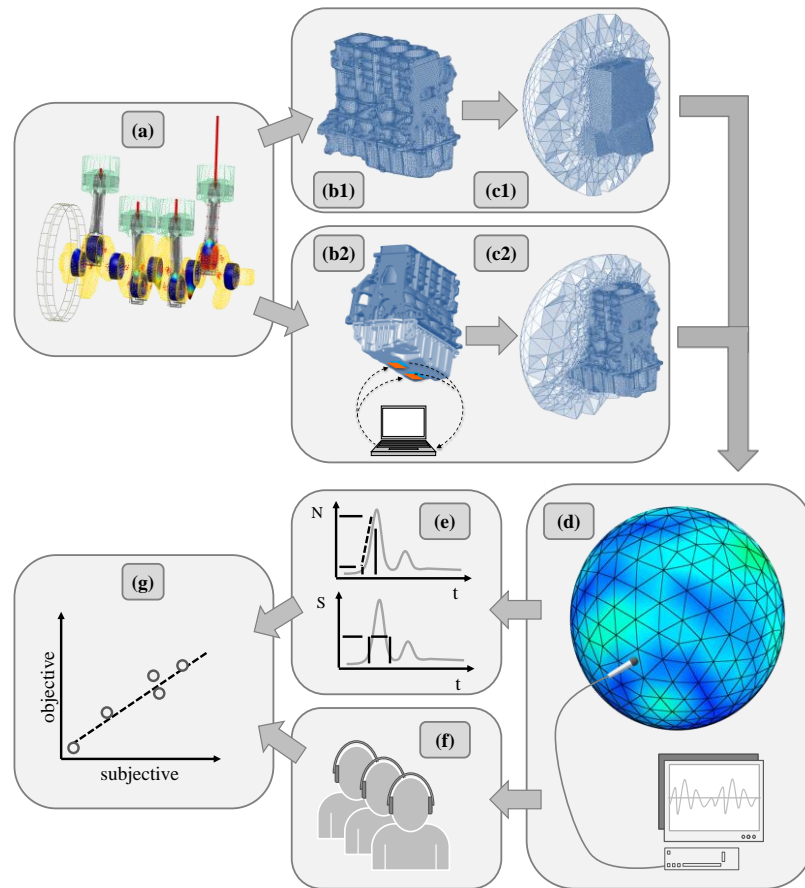

Fig. 1 Draft of the overall simulation workflow to evaluate the acoustic behavior of a combustion engine:

- (a) Excitation analysis of the engine by the gas forces with the help of an elastic MBS approach including elasto-hydrodynamic interactions [2]
- (b) Vibration analysis with the help of a complex finite element model (b1 – passive methods, b2- active methods)
- (c) Analysis of the pressure distribution in the surrounding air with the help of acoustic FEM approach (c1 – passive methods, c2- active methods)
- (d) Auralization of the acoustic simulation results
- (e) Mathematical analysis of the sounds to calculate psychoacoustic parameters
- (f) Psychoacoustic evaluation of the radiated noise with the help of hearing tests and hearing models
- (g) Generation of a robust regression model to predict the human auditory perception with the help of the best suited calculable parameters

3. EXPERIMENTAL BASIS

There is a large selection of the devices available in our laboratories to measure vibration and noise of structures. The measurements are mainly applied to evaluation and improvement of developed numerical simulation approaches. The structure vibration is mainly measured contact free with the help of one, two or three laser-scanning vibrometers. In Fig. 4 three laser heads are used to measure the three-dimensional vibration of a car body. For the sound pressure measurements the acoustic holography and visualization through the acoustic camera is applied. Likewise, several microphones and microphone arrays are available for noise source localization purposes. For the acoustic measurements two anechoic chambers can be used (see Fig. 2). The testing of active controlled structures is performed with help of a dSpace system.

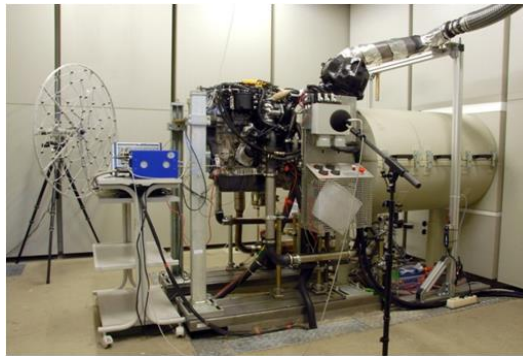

Fig. 2 Acoustic engine test bench



Fig. 3 Laser vibrometer, © IKAM

4. PASSIVE CONCEPTS FOR REDUCTION OF THE VEHICLE ENGINE NOISE

In the following section the acoustic behavior of combustion engines is analyzed and improved by applying the proposed holistic virtual engineering approach, which is shown in Fig. 4. The engine vibration is caused by the gas pressure forces of the combustion process, which excites the piston motion. The gas pressure curve does not have to be obtained by measuring the current engine prototype. It can be taken out from a representative data base of previous engines. Alternatively, the gas pressure curve can be taken from the combustion process design because this curve is available very early in the development process and furthermore virtually coincides with the real gas pressure curve of the final design. The piston motion causes the excitation of the cylinder crankcase by the internal cylinder pressure, the forces in the crankshaft main bearings and the piston contact with the cylinder walls. The calculation of the piston lateral motion and the piston tilting requires the consideration of the hydrodynamic fluid film reactions as well as the solid contact of piston and cylinder [2, 17]. The multi-body simulation (MBS) has to be carried out with at least five operating cycles of the engine, from which only the last one is taken into account as input for the subsequent vibration analysis to avoid initial disturbances in the calculated time signals of the excitation loads. The resulting signals are periodical. For this reason, it is possible to extend the time signals by repeating the representative

excitation from one operating cycle into the next. A longer time signal is advantageous for the Fast Fourier Transform (FFT), which is necessary for transforming various excitation sources into the frequency domain. Both contact parts (piston and cylinder) are modeled as elastic bodies in the MBS. Therefore, they are able to capture local deformations, which result from the elasto-hydrodynamic contact [2]. The main bearing forces are received by the solution of the Reynold's differential equation. Finally, the gas forces, the contact forces and the main bearing forces are applied as loads of the cylinder crankcase model (see Fig. 1a and 1b). The feedback of the crankcase vibrations to the crankshaft and the piston motion can be neglected, as shown in [2].

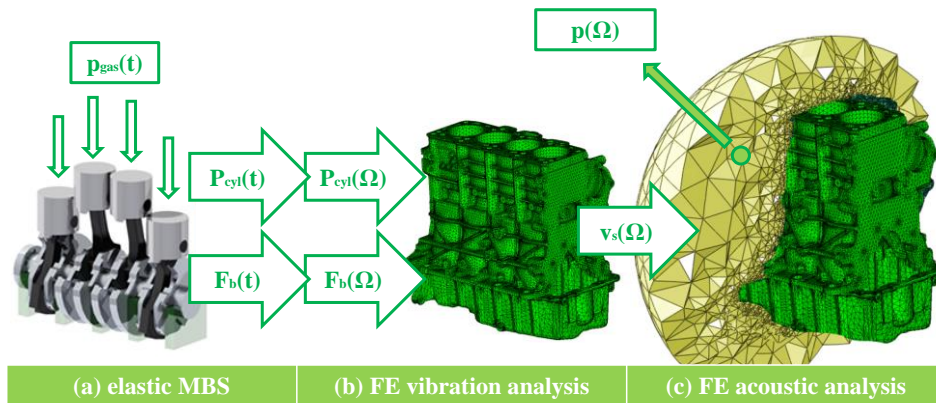

Fig. 4 Overall acoustic simulation approach of a combustion engine

The finite element method (FEM) is used for the subsequent vibration analysis of the engine. It is executed exclusively in the frequency domain in order to reduce the computational costs in comparison to a time domain approach. The bearing reactions are considered as forces and the excitations of the cylinder walls are considered as pressures to facilitate the application of the loads to the FE-mesh. The discretisation of the cylinder walls in the MBS and the FE-analysis are not coincident. The nonlinear elastic MBS of the crank drive requires the minimization of the number of degrees of freedom as far as possible due to computational costs. Therefore, in the MBS a rough discretization of the cylinder walls is used. In contrast, in the vibration analysis a detailed model of the whole cylinder crankcase and oil pan is necessary. Thus, a much finer discretization is required. Consequently, a coincident discretization of the cylinders in the MBS and in the vibration analysis has to be omitted. The resulting forces of the MBS have to be transformed into the nodes of the discretization of the vibration model. To create a static equivalent load by nodal forces on a finer discretization is simple but an energetic equivalent load requires much more effort. In the current investigations the pressure values are used as surface loads to create an equivalent load for the vibration analysis of the engine. In the vibration analysis model this surface load is defined at the midpoints of the finite element surfaces, which form the inner contour of the cylinders. The amplitude of each surface load is obtained by the elastic MBS with the help of the shape functions used for describing the pressure distribution. Therefore, the midpoints of the element surfaces of

the vibration analysis model are provided for the elastic MBS, where the shape functions of the pressure as primary variables are used to calculate the pressure values at these points. Hence, the applied loads of the vibration analysis model match exactly with the calculated loads of the elastic MBS without an additional error by the transformation between different discretizations. The transformation of the excitation of the cylinder walls in the frequency domain is executed after the calculation of the pressure values at the midpoints of the element surfaces of the vibration analysis model.

Subsequently, the vibration analysis is executed with help of these excitations to get the surface velocities of the whole engine (see Fig. 4b). These surface velocities are required as excitation of the surrounding air volume in the following acoustic analysis (see Fig. 4c). An uncoupled acoustic analysis is implemented, neglecting the feedback of the air volume to the vibrating structure, which is a common assumption because the engine is made of aluminum and consequently much stiffer than the air. The excitation of the air volume is applied as boundary condition in the calculation of the sound radiation [6]. The degrees of freedom of the structure (displacement) and the fluid (sound pressure) are coupled by special interface elements. These elements are shell type elements without stiffness or mass. They require a coincident discretization of the engine and the air volume at the fluid structure interface.

As already mentioned, the previously calculated surface velocities of the engine are applied as boundary conditions at the nodes of the interface elements. The spherical air volume is modeled with a discretization, which becomes coarser to the periphery due to the computational costs (see Fig. 1c). Generally, tetrahedrons with quadratic shape functions are used to discretize the whole engine and the air volume. The splitting of the large multi-physics system of equations into smaller problems causes a significant reduction in the computational effort. This is due to the fact that the computational effort required increases nonlinearly with the number of degrees of freedom considered. The Sommerfeld radiation condition is fulfilled by using absorbing boundary conditions [12], which is a simple and sufficient approach in comparison to the other methods, such as infinite finite elements or the Perfectly Match Layer method. To evaluate this approach a plate like structure was investigated by a comparing the numerical solution with an analytical reference solution based on the Rayleigh integral. It was shown that the three different modeling approaches to including the boundary conditions in the far field do not differ significantly.

The proposed model has been evaluated experimentally as shown in Fig. 2 and a good agreement has been recognized. Consequently, it has been used to investigate the influence of different design studies on the engine's acoustic behavior. As an example Fig. 5 compares the influence of the piston contact with the cylinder walls to the noise radiation. But, many other design configurations have been studied as well, such as the gas curves, the shape of the piston, the different axial offsets and several geometrical changes of the crank shaft and the oil sump to figure out their influence on the engine's acoustic behavior. From Fig. 5 it is seen that the oil sump at the bottom of the engine is an important noise radiator due to its large and thin surface. Therefore, several investigations to reduce the noise radiation from the oil sump have been performed. In Fig. 6 a new functionally integrated oil sump is shown and Fig. 7 presents the results of some design configurations to stiffening the bottom of the oil sump by applying an optimized configuration of ribs.

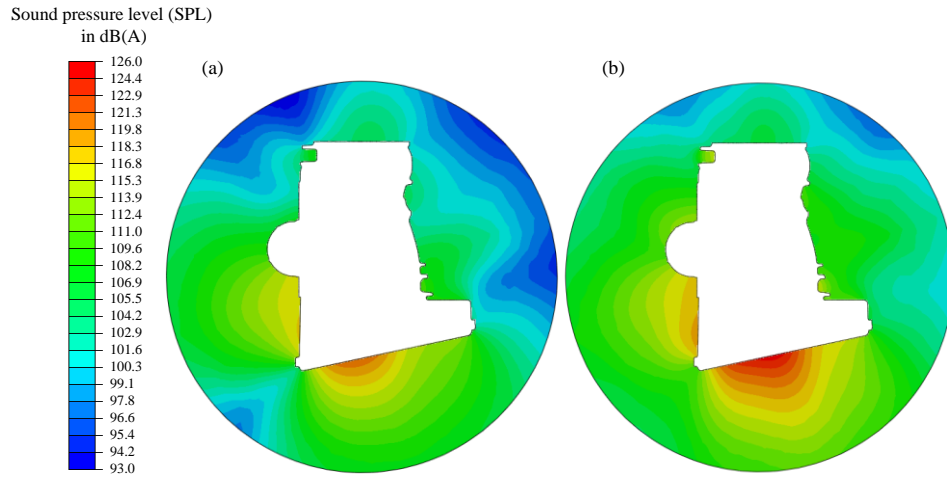

Fig. 5 Sound pressure distribution without and with consideration of the cylinder forces:
a) only bearing reactions, b) additionally the cylinder excitations are considered

But by changing the stiffness and the mass distribution only, the broad band noise level of an engine cannot be reduced properly. Therefore, as an alternative approach the development of an optimized engine encapsulation has been tested in order not only to reduce the noise radiation but also to improve the engine's heat storage capacity. From a tribological point of view the heat storage of the motor oil is of utmost importance since the oil temperature is directly related to the fuel efficiency and it contributes also to pollution reduction as well. The same overall simulation strategy can be employed by adding an additional model of the encapsulation (as seen in Fig. 1(c1)). The modeling of the encapsulation materials is not discussed here in detail, see [3]. Detailed numerical analyses have been conducted without and with different types of thermo-acoustic engine encapsulations; some results are presented in [3, 4]. The results have also been experimentally evaluated with acoustic measurements in an engine test bench as seen in Fig. 2.

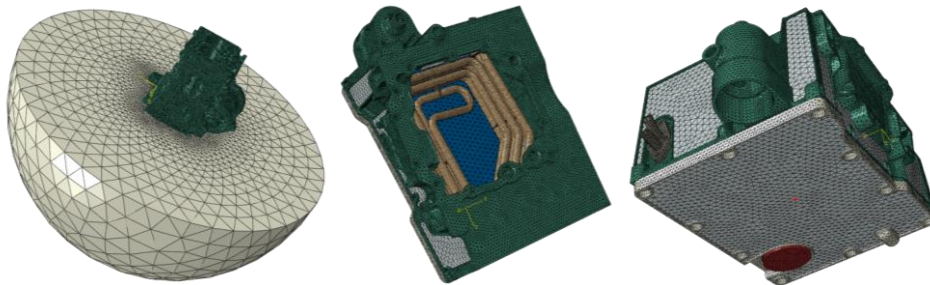

Fig. 6 Finite-element-model of the crankcase and the surrounding air-volume (left) with the new developed functionally integrated oil pan (middle, right)

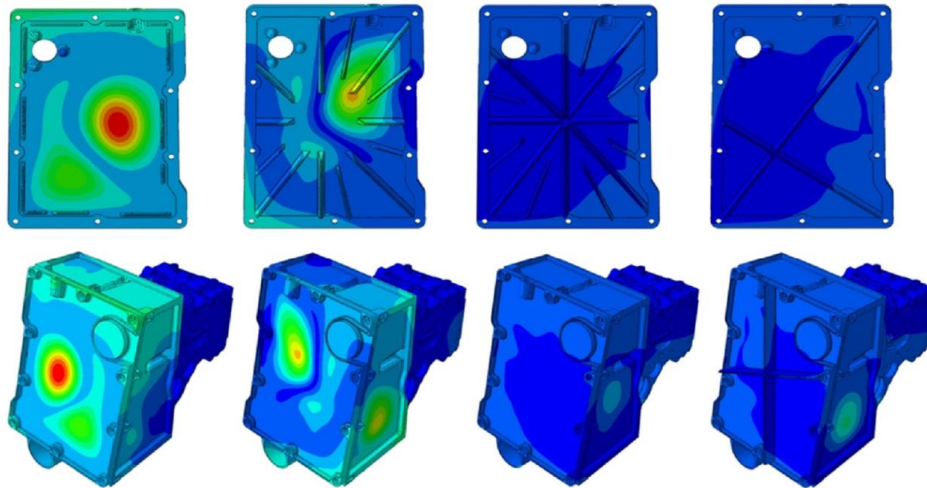

Fig. 7 Surface velocities of the oil sump with different types of ribs

From studies with different encapsulations we have learned that it is very important to avoid acoustic leakages. Also additional seals made of silicone and vibration-decoupling modifications have improved the encapsulation. In Fig. 8 (right) the measured sound pressure level shows the performance of the encapsulation.

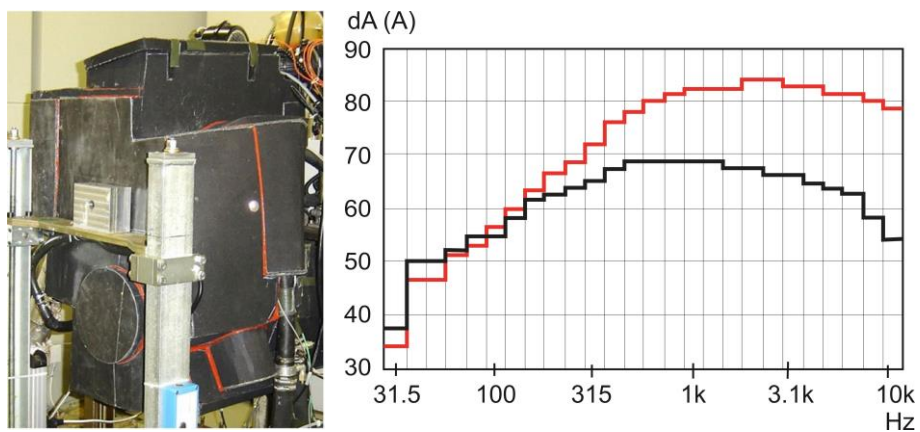

Fig. 8 Encapsulation (left); Sound power level at the thrust side:
red: without encapsulation, black: with encapsulation

The acoustic effect of the encapsulation (see Fig. 8 right) mainly occurs at frequencies higher than 100 Hz. Additionally, the stored heat improves the cold starting behavior of the engine, meaning that the optimal operating points of the engine at which wear and tear and, therefore, exhaust emissions are reduced as well, are more quickly reached. Of course, the engine overheating and overloading of the cooling circuit have to be excluded.

For thermal consideration, an FE-simulation was conducted as well. The finite element mesh was directly taken from the acoustic simulations. Only the engine oil inside the oil pan was added. It was also modeled with quadratic tetrahedrons. Fig. 9 shows comparison of the acoustic pressure of the engine without (left) and with the developed encapsulation.

During the investigations several other parts of a combustion engines have been also investigated and improved by applying the overall virtual engineering approach, e.g. the exhaust systems, the oil sumps, the air charge systems, etc.

The investigations presented above are focused on the application of insulation materials like foams, microfibers and mass layers, which are used together as multilayer systems and mounted on the vibrating surfaces in order to create a damping effect that reduces the sound radiation. The influence of the material thickness on the damping behavior was investigated as well as the influence of a thin foil adhered to the surface. We have carried out experiments and simulations which have provided us with generalized guidelines for optimizing damping materials geometry and design according to the specifications of their applications.

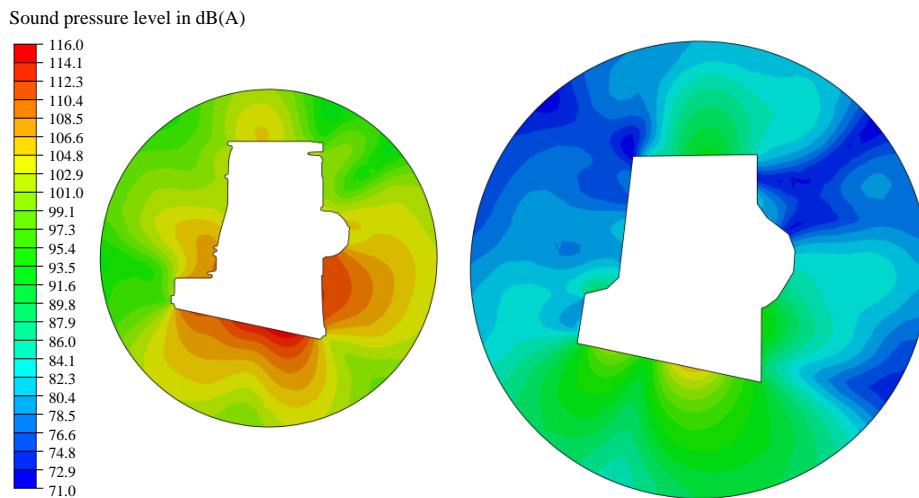

Fig. 9 Sound pressure around the engine: left: without, right: with encapsulation

5. ACTIVE PIEZOELECTRIC NOISE CONTROL

Passive damping methods mostly reduce the vibration and the sound emission of structures by modifying the structural geometry and by applying additional damping materials. These methods are well suited in a higher frequency range (see e.g. Fig. 8 right). Unfortunately, damping materials are increasing the weight. On the other hand, there are active control techniques available, which provide an alternative way to minimize unwanted structural vibrations and noise [7, 9, 11, 20, 31]. Active methods are of increasing interest to designers since they are powerful and do not considerably increase the structural weight. For the development of active systems the overall simulation methodology (see Fig. 1) can also

be applied. In the following the active noise reduction approach is demonstrated at the oil sump of a combustion engine. As we have seen the oil sump is the main noise radiator of an engine. To actively influence the vibration amplitudes of the structure piezoelectric materials are attached to the structure, and by a properly designed electric excitation the vibration amplitudes are reduced. This results additionally in a reduction of the excited amplitudes of the acoustic waves. As sensors microphones in the surrounding or structural integrated sensors (acceleration sensors or strain gauges) can be used. For modeling the structural behavior the electromechanical coupled field equations have to be taken into account in the finite element model [8, 11, 22]. But for design purposes it is also meaningful to include the control as well in the finite element simulation [30]. But also software in the loop approach, as it is proposed by Orszulik and Gabbert [27], can be applied. As an advantage of this approach the extensive control strategies can be designed in Matlab/Simulink and applied during the overall simulation process. Also the prior knowledge about the excitation, such as the gas forces, can be used to design an optimal control technique with additional dynamics [23].

In Fig. 10 left the finite element model of the crankcase with the oil pan is shown. The pictures show that two collocated actuators and a sensor are applied to the bottom of the oil sump. The placement of the actuators and the sensor are numerically identified with the help of the most dominant mode shapes [31]. In Fig 10 (right) a photo of the outer surface of the oil sump is shown, which is used for experimental investigations. At the photo the two applied piezoelectric patch actuators are shown together with extra acceleration sensors for additional test reasons. In Fig. 11 the computed and the measured sound pressure distributions of the uncontrolled and the controlled engine are plotted at the most dominating resonance frequency of 975 Hz. The measurements have been carried out in a free-field room with the help of a uniformly distributed microphone-array. From Fig. 11 it can be seen that the simulation results correlate very well with the experimental ones. In the active damping case a velocity feedback control was used in the simulation as well as in the measurement, where the applied voltage was about 10 V [32].

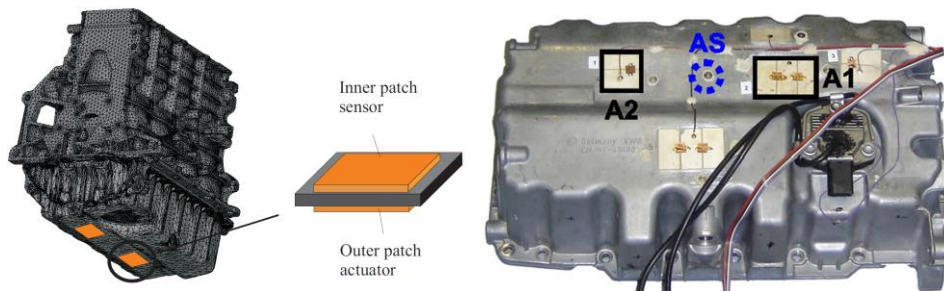

Fig. 10 Finite element model of the crankcase with the oil sump with two collocated pairs of actuators and sensors (left); right: photo of the oil sump outer surface equipped with two piezoelectric actuators (A1, A2) and additional acceleration sensors (AS)

The simulations and the measurements have been performed at a stripped engine. At the most dominating first eigenfrequency a noise reduction of about 16 dB and at the second eigenfrequency of about 10 dB was achieved in comparison to the uncontrolled case. In order to evaluate the quality of the developed actively controlled oil sump

additional experimental tests were performed on an acoustic engine test bench (Fig. 1) under real operating conditions [20]. The behavior of the controlled and the uncontrolled case was measured at engine run-ups from 900 to 3000 rpm. The measurements reveal that due to the controller influence the amplitudes of the sound pressure in the resonance frequency regions of the oil pan are reduced by approximately 4 dB, which indicates the noise reduction potential of the designed system.

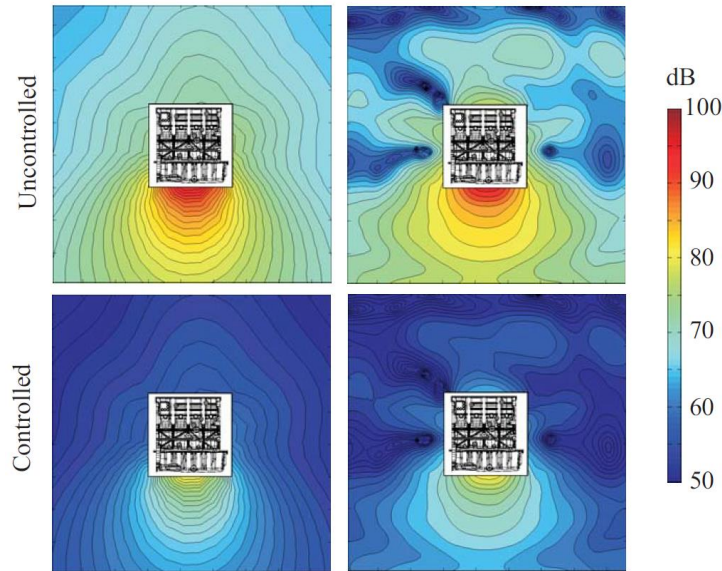

Fig. 11 Sound pressure distribution around the engine: simulation (left), measurement (right)

6. PSYCHOACOUSTIC EVALUATION

Instead of measuring the acoustic behavior of a real prototype [1, 26, 29], the presented overall numerical simulation methodology is used to receive audible sounds of the engine [5]. These audible sounds are used to carry out paired comparison listening tests, which finally lead to an interval scaled ranking of the stimuli. These data from listening tests are used to create a psychoacoustic mathematical model which shows the highest correlation with the subjective evaluation of engine sounds. This psychoacoustic model is a function, which consists of a weighted combination of well-chosen classical psychoacoustic parameters, such as loudness and sharpness. The resulting psychoacoustic model describes and predicts the auditory sensation of the noise quality on the basis of a signal processing of the sound signal only - without any further auralization or hearing test. The advantage of such a concept is that the perceived quality of an engine can be optimized before a real prototype is built because only simulation results are needed as input for the psychoacoustic model. For the details of the approach the reader is referred to [14], [15, 5]. The psychoacoustic approach has been developed and applied first to

impulsive vehicle sounds such as the door locking and closing noise and the flasher noise [14]. This approach has been recently extended to engine noises [5]. We have found out that for generating a proper psychoacoustic model three parameters are sufficient to generate a robust and quite precise mathematical model by linear regression. In this example these three parameters are (i) maximum gradient of percentile loudness N_5 , (ii) maximum sharpness S_{max} and (iii) duration of sharpness T_S [5]. With such a model different types of combustion engines and different types of engine encapsulation have been evaluated in order to optimize their acoustic behavior. Fig. 12 shows the distribution of the sound pressure around a combustion engine enclosed with an encapsulation. The A-weighted sound pressure is compared with the results received by the developed psychoacoustic model for the perceived quality of the engine sounds. It has been carefully proved by additional hearing tests that the developed model is very well suited to describing the human sensation of the sound quality of different engines without further hearing tests. It is very important to consider more complex psychoacoustic models to evaluate the acoustics of engines properly; an evaluation with only single basic parameters is not sufficient enough to describe the sound quality.

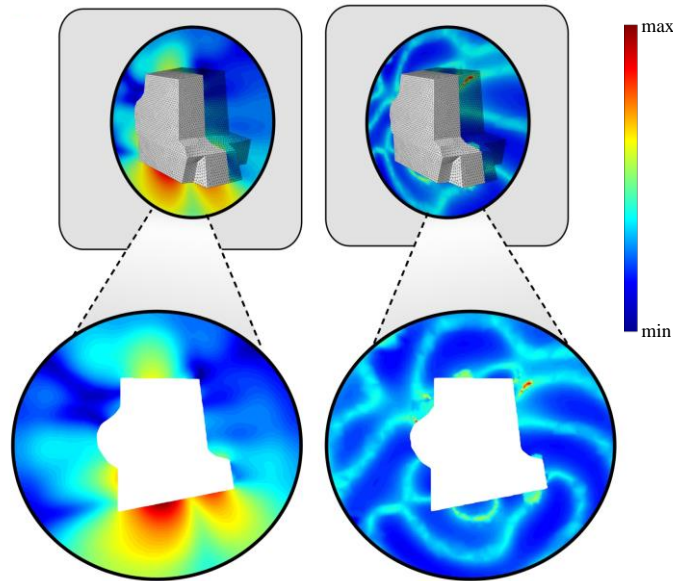

Fig. 12 The A-weighted sound pressure level (left) and the perceived sound quality (right)

7. EXTENSION TO ELECTRIC DRIVES

The presented overall simulation approach can also be extended and successfully applied to electric drives for electro-cars. Recently, an electric wheel hub motor for electrically driven cars has been developed [16], which shows an extraordinary power-to-weight-ratio, as it combines two different types of winding to boost torque sharing the same magnetic circuit; one is an air gap winding and the other one is a slot winding, see Fig. 13.

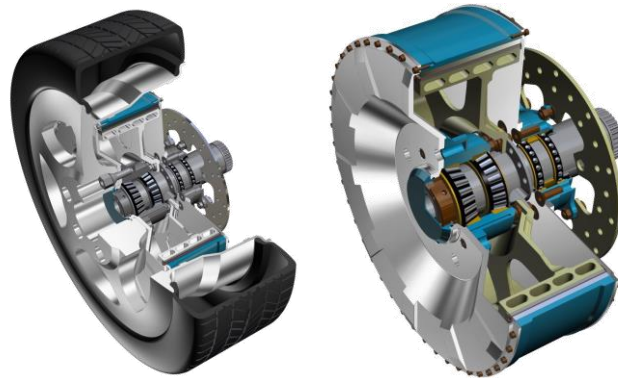

Fig. 13 Design of the electric wheel hub motor [16]

In the development process of an electric engine acoustics is usually not in the focus of interest. But it has been proven that the acoustic characteristics of electric engines are a very important topic, which should be taken into account at an early stage of the development process. In contrast to combustion engines in electrical engines the first engine orders are related to much higher frequencies (up to 1250 Hz) and the resulting sound is not so noisy. In general it seems that the radiated sound is caused by a few different frequencies only, as the second and the third engine order are the most important engine orders beside the first order, but even their amplitudes are with about 5% and 2% of the first one still comparably small. Hence, the emitted sound of an electric engine is more like a single high frequency tone. Unfortunately, the human auditory perception is very sensitive with respect to such high frequency sounds. Consequently, the noise emission of electric engines is more annoying than the noise emission of combustion engines, even if the amplitudes of the electric sound are lower. For this reason, it is important to consider the acoustic behavior as early as possible in the product development process of an electric engine. With the aid of our overall simulation workflow the acoustics of electric engines can also be optimized before the first prototype is built.

The first part of the workflow (see Fig. 1) is changed because the excitation is now caused by magnetic forces. Therefore, the electromagnetic behavior is modeled first, where it is common to neglect the differences in the direction of the rotation axis to increase efficiency. It is sufficient to use a two dimensional model only (see Fig. 14, right upper corner), as the attenuation of the tangential magnetic forces is less than 5% at the borders. Further, the magnetic forces in radial direction are non-linear and cause stability problems if they are linearized. The electromagnetic forces resulting from the first step are used to calculate vibration behavior of the wheel hub motor. This results in the surface velocity, which is used to excite the surrounding air and to calculate the air pressure at any point of the surrounding air volume under free field conditions.

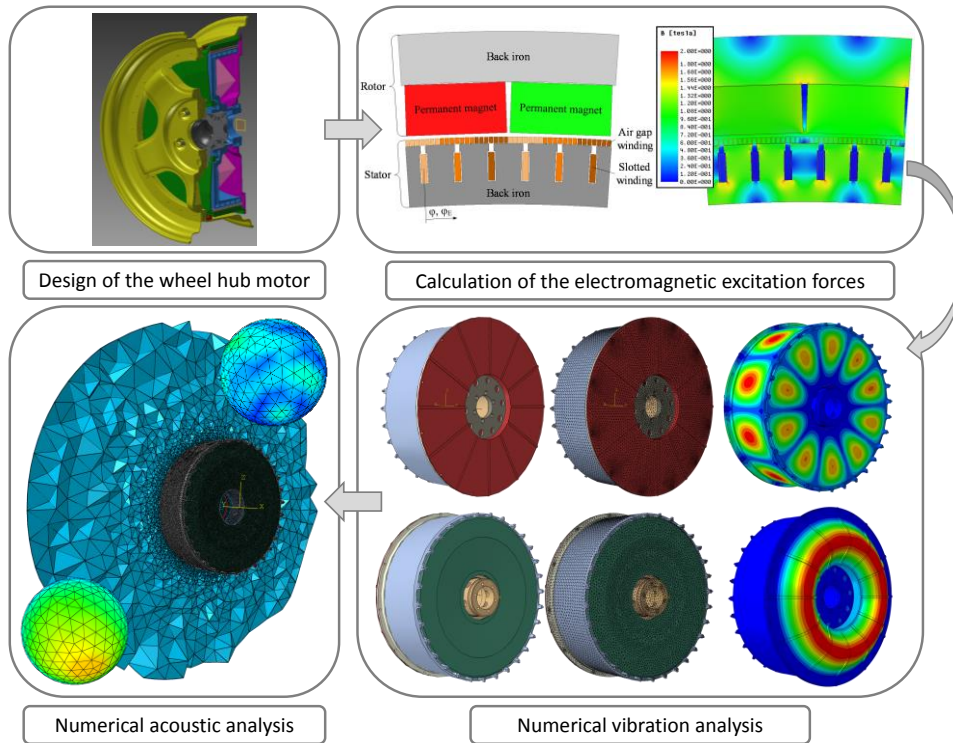

Fig. 14 Holistic simulation workflow for calculating the sound radiation of an electric wheel hub motor based on the electromagnetic excitation forces

The vibration and acoustic analyses can be solved in an uncoupled manner, as the feedback of the vibrating air on the much stiffer engine housing can be neglected. For all three solution steps, the electrodynamics, the structural dynamics and the acoustics the finite element method are used. In the vibration and acoustic analyses tetrahedral elements with quadratic shape functions are used due to the complex geometry and the required accuracy which is tested by convergence studies. The acoustic simulations can be done with a much coarser mesh due to the larger wave length in the air. But, at the interface between the structure and the air volume it is appropriate to use a coincident mesh, which is coarsened with increasing distance from the structure to reduce the computational effort of the approach. The developed and numerically tested overall workflow is finally also validated by measurements.

The presented overall virtual engineering methodology can be used to optimize the design of the wheel hub motor in further steps in order to fulfill its acoustic requirements. Furthermore, it would be a promising future development to extend the overall workflow by a psychoacoustic post-processing as shown in Section 6 in order to include the special properties of human hearing sufficiently, instead of determining the classical acoustic parameters such as the sound pressure level.

8. CONCLUSIONS

In the process of engine development, the reduction of the sound emission is a major objective together with the optimization of both the power and the fuel efficiency. Hence, in the paper at hand the aim was to present a recently developed overall virtual prediction methodology that can evaluate the sound quality of engines based on auralized simulation results. This methodology consists of numerical and psychoacoustic analyses. It has been originally developed and tested for combustion engines but it is also capable to be applied to electric engines. The numerical analysis begins with the calculation of the excitation forces. Then, the determined excitation forces are used to calculate the vibrations of the engine with the help of the finite element method. Subsequently, the resulting acoustic behavior is calculated and rendered audible. At this point, the psychoacoustic part of the analysis begins, where the signal processing of the resulting time signals from the numerical simulations is performed in order to calculate appropriate psychoacoustic parameters. The numerically calculated engine sounds are also used to carry out hearing test with human participants, who evaluate different engine sounds with respect to their perceived sound quality. Finally, the results of the signal analysis and the hearing test are compared by regression and correlation analyses. The objective parameters with the best correlation between the results of the signal analysis and the hearing test are used to generate a psychoacoustic prediction model of the perceived sound quality. The generated psychoacoustic prediction model and the numerical results are validated by experimental investigations. The remarkable feature of the presented approach is that the auralized simulation results are used within the hearing tests instead of the sounds of real engines or prototypes. This makes it possible to execute the presented workflow early in the product development process. This means that no hardware or real prototypes are required in order to evaluate the result of engine modifications on the acoustic behavior and its corresponding human perception. Hence, the presented concept is suitable for computer based optimization of the engine with respect to the perceived sound quality. To demonstrate the developed workflow the results of the holistic approach applied to combustion engines are presented. It is shown that the application of engine encapsulations can reduce the sound emission of combustion engines significantly. With the help of the developed approach it is possible to make decisions regarding the geometry of the engine structure, a proper damping material for an encapsulation, its layout and thickness, as well as the optimal shape of the encapsulation. Besides passive means, which are preferable in the higher frequency range, additionally, active control methods are also briefly discussed. Finally, it is shown how the overall simulation approach is extended to electric machines and applied to simulate the acoustic behavior of a recently developed new wheel hub motor.

Acknowledgements: *The presented work is part of the joint project COMO III (COmpetence in MObility), which is financially supported by the European Union through the European Funds for Regional Development (EFRE) as well as the German State of Saxony-Anhalt (ZS/2016/04/78118). This support is gratefully acknowledged. Furthermore, we would like to thank Dr. Christian Daniel for subfigure 1(a). Moreover, we want to acknowledge the cooperation with the Chair of Technical Dynamics. We would also like to thank the Chair of Mobile Systems of Prof. Rottengruber for providing the engine test bench and the support during the acoustic measurements. Finally, we want to acknowledge the cooperation with the Chair of Mechatronics of Prof. Kasper for providing the CAD-models of the electric wheel hub motor.*

REFERENCES

1. Altinsoy, M., Ferling, M., Jekosch, U., 2012, *The semantic space of vehicle sounds: developing a semantic differential with regard to customer perception*, Journal of the Audio Engineering Society, 60(1-2), pp.13–22.
2. Duvigneau, F., Nitzschke, S., Woschke, E., Gabbert, U., 2016, *A holistic approach for vibration and acoustics analysis of combustion engines including hydrodynamic interactions*, Archive of Applied Mechanics, 86(11), pp. 1887–1900.
3. Duvigneau, F., Luft, T., Gabbert, U., Hots, J., Verhey, J., Rottengruber, H., 2016, *Thermo-acoustic performance of full engine encapsulations - A numerical, experimental and psychoacoustic study*, Applied Acoustics, 102, pp.79-87.
4. Duvigneau, F., Koch, S., Woschke, E., Gabbert, U., 2016, *An effective vibration reduction concept for automotive applications based on granular-filled cavities*, Journal of Vibration and Control, pp. 1-10, doi.org/10.1177/1077546316632932
5. Duvigneau, F., Liefold, S., Höchstetter, M., Verhey, J. L., Gabbert, U., 2016, *Analysis of simulated engine sounds using a psychoacoustic model*, Journal of Sound and Vibration, 366, pp. 544-555.
6. Everstine, G. C., 1971, *Finite element formulations of structural acoustics problems*, Comput. Struct. 65(3), pp. 307–321.
7. Fuller, C.R., Elliott, S.J., Nelson, P.A., 1996, *Active control of vibration*, Academic Press, London.
8. Gabbert, U., Nestorović-Trajkov, T., Köppe, H., 2006, *Finite element based overall design of controlled smart structures*, Journal of Structural Control and Health Monitoring, 13, pp. 1052-1067.
9. Gabbert, U., Nestorović-Trajkov, T., Wuchatsch, J., 2008, *Methods and possibilities of a virtual design for actively controlled smart structures*, Computers and Structures, 86, pp. 240-250.
10. Gabbert, U., Lefèvre, J., Laugwitz, F., Nestorović, T., 2009, *Modelling and analysis of piezoelectric smart structures for vibration and noise control*, Int. J. of Applied Electromagnetics and Mechanics, 31(1), pp. 29-39.
11. Gabbert, U., Lefèvre, J., Ringwelski, S., 2009, *Active noise control of thin-walled structures*, in Cunha, A., Rodrigues, D.J. (Eds.): *Proceedings of the IV ECCOMAS Thematic Conference on Smart Structures and Materials – SMART'09*, 13.15 July 2009, Porto, Portugal, pp. 269-280.
12. Givoli, D., 2008, *Computational Absorbing Boundaries*, in Marburg, S., Nolte, B., (Eds.): *Computational Acoustics of Noise Propagation in Fluids*, Springer, Berlin.
13. Gu, Y., Fuller, C.R., 1993, *Active control of sound radiation from a fluid-loaded rectangular uniform plate*, Journal of the Acoustical Society of America, 93, pp. 337–345.
14. Höchstetter, M., Sautter, J.-M., Gabbert, U., Verhey, J., 2016, *Role of duration of sharpness in the perceived quality of impulsive vehicle sounds*, Acta Acustica united with Acustica, 102(1), pp. 119-128.
15. Höchstetter, M., Wackerbauer, M., Verhey, J., Gabbert, U., 2015, *Psychoacoustic prediction of singular impulsive sounds*, ATZ worldwide, 117(7-8), pp. 58-63.
16. Kasper, R., Borchardt, N., 2016, *Boosting power density of electric machines by combining two different winding types*, in Proceedings of MECHATRONICS 2016:7th IFAC Symposium on Mechatronic Systems & 15th Mechatronics Forum International Conference, Loughborough University, 5th - 8th September 2016, IFAC, Art. WeP3T1.2, pp. 322-329.
17. Knoll, G., Peeken, H., Lechtape-Grüter, R., Lang, J.R., 1996, *Computer-aided simulation of piston and piston ring dynamics*, J. Eng. Gas Turbines Power, 118(4), pp. 880–886.
18. Lee, H. -K., Park Y. -S., 1996, *A near-field approach to active control of sound radiation from a fluid-loaded rectangular plate*, Journal of Sound and Vibration, 196(5), pp. 579–593.
19. Li, S., Zhao, D., 2004, *Numerical simulation of active control of structural vibration and acoustic radiation of a fluid-loaded laminated plate*, Journal of Sound and Vibration, 272(1-2), pp. 109–124.
20. Luft, T., Ringwelski, S., Gabbert, U., Henze, W., Tschöke H., 2011, *Active reduction of oil pan vibrations on a four-cylinder diesel engine*, in Proceedings of the International Automotive Acoustic Conference, Zürich, July 7-8, 2011, paper 7, 14 p.
21. Marburg, S., 2002, *Developments in structural-acoustic optimization for passive noise control*, Archives on Computational Methods in Engineering, 9(4), pp. 291–370.
22. Marinković, D., Köppe, H., Gabbert, U., 2006, *Numerically efficient finite element formulation for modeling active composite laminates*, Mechanics of Advanced Materials and Structures, 13(5), pp. 379 - 392.
23. Nestorović-Trajkov, T., Köppe, H., Gabbert, U., 2005, *Active vibration control using optimal LQ tracking system with additional dynamics*, International Journal of Control, 78(15), pp. 1182-1197.

24. Nestorović-Trajkov, T., Seeger, F., Köppe, H., Gabbert, U., 2006, *Optimal LQ controller with additional dynamics for the active vibration suppression of a car roof*, Facta Universitatis, Series: Mechanics, Automatic Control and Robotics, 5(1), pp.117-129.
25. Nelson, P.A., Elliott, S.J., 1992, *Active control of sound*, Academic Press, London.
26. Nykänen, A., Johnsson, R., Sirkka, A., Johansson, Ö., 2013, *Assessment of changes in preference ratings of auralized engine sounds caused by changes in frequency resolution of transfer functions*, Journal of Applied Acoustics, 74, pp. 1343–1353.
27. Orszulik, R., Gabbert, U., 2016, *An interface between Abaqus and Simulink for high-fidelity simulations of smart structures*, IEEE/ASME Transactions on Mechatronics, 21(2), pp. 879-887.
28. Orszulik, R. R., Duvigneau, F., Gabbert, U., 2017, *Dynamic modeling with feedforward/feedback control design for a 3 dof piezoelectric nanopositioning platform*, Journal of Intelligent Material Systems and Structures, pp. 1-9, DOI: 10.1177/1045389X17704063.
29. Otto, N., Simpson, R., Wiederhold, J., 1999, *Electric vehicle sound quality*, SAE Technical Paper 1999-01-1694, doi:10.4271/1999-01-1694.
30. Ringwelski, S., Gabbert, U., 2010, *Modeling of a fluid-loaded smart shell structure for active noise and vibration control using a coupled finite element-boundary element approach*, Smart Materials and Structures, 19(10), 105009, 13pages.
31. Ringwelski, S., Luft, T., Gabbert, U., 2011, *Piezoelectric controlled noise attenuation of engineering systems*, Journal of Theoretical and Applied Mechanics, 49(3), pp. 859-878.
32. Ringwelski, S., Zornemann, M., Luft, T., Gabbert, U., 2012, *Active control of noise and vibration on a combustion engine*, Proceedings of the ICSV19, Vilnius, Lithuania, July 08-12, 2012, 8 pages.
33. Ruckman, C.E., Fuller, C.R., 1994, *Numerical simulation of active structural-acoustic control for a fluid-loaded spherical shell*, Journal of the Acoustical Society of America, 96, pp. 2817–2825.